



ADTECH

Analog-Digital Technology, Inc.

3750 Monroe Avenue
Pittsford, New York 14534-1302
(716) 383-8280 • FAX (716) 383-8386

TCA 104 – TCA 105

T/C Alarms

Instruction Manual

1.0 INTRODUCTION

These instructions refer to the above models. Supplementary sheets are attached if the unit has special options or features. For detailed specifications, refer to the Data Bulletin. All ADTECH instruments are factory calibrated and supplied with a label detailing the calibration. Adjustments are normally not necessary. A simple check should be performed to verify calibration before installation to ensure that it matches the field requirement.

2.0 GENERAL DESCRIPTION

The ADTECH TCA 104/TCA 105 series of alarms are single or dual alarms that accept an input signal of any ISA T/C type and range and provide relay contact output(s).

The TCA 104 is a single alarm providing a DPDT output and the TCA 105 is a dual alarm providing 2 SPDT outputs as standard. DPDT output for TCA 105 is optionally available and requires the "Wide Line" enclosure.

The single alarm may be a Hi or Low alarm; the dual alarm may be Hi-Low, Low-Hi, Hi-Hi or Low-Low. Internal jumpers determine the proper relay(s) action.

The relay coil may be power fail safe (i.e.) energized for normal conditions or NON-power fail safe (i.e.) energizes on alarm conditions.

Unless otherwise specified, the single alarm is set as Hi trip, power fail safe and the dual alarm as Hi-Low trip, power fail safe.

Red/Green LED indicator for each relay is provided as standard. Green indicates normal condition and red indicates alarm condition.

3.0 INSTALLATION

The instrument is supplied in a general purpose enclosure as standard. NEMA 4, 7 or 12 and plug in chassis enclosures are optionally available. Installation area/location must agree with the supplied instruments including operating temperature and ambient conditions.

Mounting

Refer to the appropriate outline drawing for mounting and clearance dimensions. The instrument is surface mounted with two #10-32 screws on 8.00 inch centers.

Electrical Connections

The wire used to connect the instrument to the control system **Input/Output** should be a twisted pair(s) and sized according to normal practice. Shielded cable is not normally necessary (if used, the shield must be grounded at the ADTECH instrument and left floating at the sensor).

A 12 position barrier terminal block with #6-32 screws and 3/8" spacing is provided for I/O and power connection. A housing ground terminal for grounding is also provided.

Controls

Multiturn ZERO, SPAN and Internal COLD JUNCTION COMPENSATION controls are provided to calibrate the ALARM. Multiturn trip set control(s) is provided to set the trip point(s) level on all units. Adjustable deadband may also be provided if specified. If optional calibrated dial(s) for trip set and/or adjustable deadband control(s) is supplied, they are normally mounted in the "Wide Line" enclosure.

The multiturn control(s) is accessible through the instrument front panel and is clearly marked for ease of use.

4.0 MAINTENANCE

These instruments are electronic except for the relay(s) output(s) and require no maintenance except for periodic cleaning and calibration verification. The standard relay is rated by the manufacturer for 500,000 10 amp operations at 30 vdc and 2x10⁷ mechanical operations. Relay output(s) should be verified at user established time intervals. If the unit appears to be mis-operating it should be checked in place per section 6.0 or removed for a bench check per sections 6.0 and 7.0. MOST problems are traced to field wiring and/or associated circuits. If the problem appears to be within the instrument, proceed to sections 6.0 and 7.0.

5.0 CONNECTIONS

Standard connections are shown below and on the instrument face plate, Data Bulletin or on attached supplementary sheets.

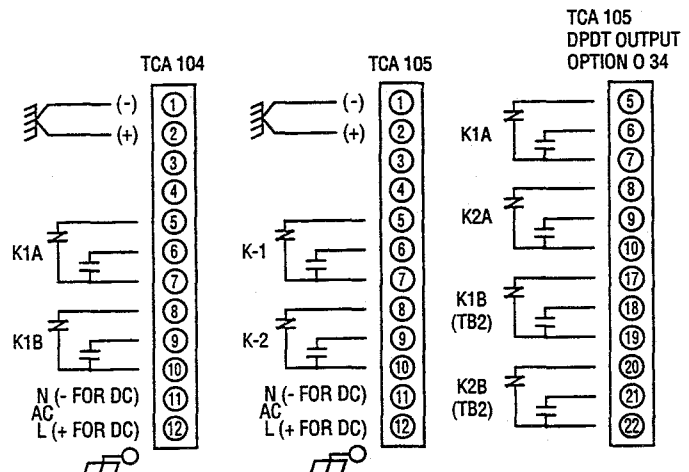

CAUTION: NO customer connection to Terminal No. 3

DO NOT remove or reverse the factory installed Cold Junction Compensation network at Terminals No. 3 and 4

6.0 SET UP AND CALIBRATION

All ADTECH units are factory calibrated per your instructions. Usually, a complete recalibration is not required unless it is required to change input types, relay action, or the range of the unit. Most calibrations will only require an alarm SET POINT adjustment and the associated options like adjustable DEAD BAND or TIME DELAY.

The calibration process is broken into 5 separate steps as follows:

Input and Output Configuration	Sec 6.1
Determining the MAJOR RANGE setting	Sec 6.2
Determining the COARSE ZERO and SPAN settings	Sec 6.3
FINE ZERO and SPAN adjustment	Sec 6.4
Alarm SET POINT, DEAD BAND, and TIME DELAY adjustment.....	Sec 6.5

6.1 INPUT AND OUTPUT CONFIGURATION

6.11 INPUT CONFIGURATION

The ATECH Series 100 Thermocouple input alarms, TCA 104/105 provide standard setups for the eight most common T/C types (E, J, K, T, N, R, S, and B). To set the T/C type follow the jumper settings found in Table 5 for your particular application.

Also, the TCA 104/105 alarms provide for upscale or downscale T/C burnout. Refer to Table 4 to select jumper, J4 to set the desired burnout type.

6.12 OUTPUT CONFIGURATION

All ADTECH series 100 alarms allow the customer to change the factory set relay action. The Alarm(s) may be configured for LOW alarm (Alarm condition when the input falls below the set point) or HIGH alarm (Alarm condition when input rises above the set point) as required by your particular application. Table 1 shows the jumper(s) setting required to set the appropriate alarm type.

In addition to the alarm type, the mode in which the relay is energized may be changed. The Relay(s) may be either energized in a FAILSAFE mode (Relay energized under normal, non alarm conditions) or NON-FAILSAFE mode (Relay De-energized under normal, non alarm conditions) as per the application. Use Table 1 to set the jumper(s) as required.

6.13 COMMON EXAMPLES

Example 1 – Single Alarm (K1), High Alarm and Failsafe.

- Jumper J03 set to position A, sets the High Alarm type for relay K1.
- Jumper J01 set to position A, sets the relay to be energized in the Failsafe Mode.

Example 2 – Dual Alarm (K1 and K2), K1 – High Alarm and Failsafe; K2 – Low Alarm and Failsafe.

- Jumper J03 set to position A, sets the High Alarm type for relay K1.
- Jumper J01 set to position A, sets the Relay K1 to be energized in the Failsafe Mode.
- Jumper J04 set to position B, sets the LOW Alarm type for relay K2.
- Jumper J02 set to position A, sets the Relay K2 to be energized in the Failsafe Mode.

6.2 DETERMINING MAJOR RANGE

The ADTECH 100 Series of Alarms is designed to provide a wide input range compatibility. This is accomplished with a technique that first conditions the input to a MAJOR RANGE. This ranging technique assures the highest performance from our units and maintains a standard, easy to use calibration method. You can then elevate or suppress up to 85% of the MAJOR RANGE with the COARSE ZERO settings, and also scale to less than 15% of the MAJOR RANGE with the COARSE SPAN settings. The FINE ZERO and SPAN controls provide 12% adjustment of the MAJOR RANGE.

The input SPAN and ZERO values are used to select the MAJOR RANGE from table 4. The MAJOR RANGE is determined from the larger of the SPAN, or ZERO x 1.17 (ignoring the sign) as per the following examples.

Example 1: Input of 1-15 millivolt

$$\text{SPAN} = (15 - 1) = 14$$

$$\text{ZERO} = 1 \times 1.17 = 1.17$$

Span dominates the selection in this case. You would select the MAJOR RANGE that is greater than or equal to 14 mvdc from table 6 (selected value 20 mvdc).

Example 2: Input of 40 to 60 mvdc

$$\text{SPAN} = (60 - 40) = 20$$

$$\text{ZERO} = 40 \times 1.17 = 46.8$$

This example shows the selection based on the ZERO value. From table 6, you would select a MAJOR RANGE of 80 mvdc.

6.3 COARSE ZERO AND SPAN SETTINGS

Once the MAJOR RANGE is selected, one can determine the COARSE ZERO and SPAN settings. The procedure involves dividing both the ZERO and SPAN values by the MAJOR RANGE to determine a percentage. Then look up the proper settings from tables 2 and 3. We will use values from the first example above to illustrate the procedure.

Example 1: Input of 1 to 15 mvdc

$$\text{SPAN of } (15 - 1) = 14$$

$$\text{ZERO of } 1 \times 1.17 = 1.17$$

$$\text{MAJOR RANGE of } 20 \text{ mvdc}$$

$$\% \text{SPAN of MAJOR RANGE } (14/20) \times 100\% = 70\%$$

$$\% \text{ZERO of MAJOR RANGE } (1/20) \times 100\% = 5\%$$

Simply find the range that includes the percentages you just calculated in the appropriate table.

6.4 FINE ZERO AND SPAN ADJUSTMENT

The FINE ZERO and SPAN controls provide an adjustment of 12% of the MAJOR RANGE selected. This is an internal adjustment. You will need a voltmeter with resolution to 1 mV to do the fine adjustment. The procedure is as follows:

6.41 Connect the voltmeter from GND(-) to VNORM1(+) on the test point header H3 (Refer to figure 2 for locations.) Apply ZERO input to the unit, and adjust the ZERO ADJ. potentiometer until the meter reads 0 Vdc +/- 2 mV.

6.42 Connect the voltmeter from +VR(-) to VNORM1(+) on the test point header. Apply full scale to the unit, and adjust the SPAN ADJ. potentiometer until the meter reads 0 Vdc +/- 2 mV.

6.43 Recheck ZERO and SPAN values per step 1 and 2 above, and adjust the appropriate controls as necessary.

6.5 ALARM SET POINT, DEAD BAND AND TIME DELAY ADJUSTMENT

Alarm SET POINT, and the optional DEAD BAND and TIME DELAY controls are accessed from the front of the unit. The adjustment procedure is described for one alarm, and applies to each alarm of a dual alarm unit.

6.51 SET POINT

The Alarm SET POINT adjustment is made by applying the desired input value, and adjusting the SET POINT potentiometer until the alarm changes from normal (GREEN LED indication) to alarm (RED LED indication). IT IS VERY IMPORTANT that the potentiometer be adjusted from the non-alarm condition to the alarm condition to insure the proper alarm setting.

TABLE 1
RELAY ACTION JUMPER SELECTION

RELAY CONFIGURATION	RELAY	
	K1	K2
Low Alarm	JO3=B	JO4=B
High Alarm	JO3=A	JO4=A
Non-Failsafe	JO1=B	JO2=B
Failsafe	JO1=A	JO2=A

TABLE 2
COURSE SPAN

PERCENT OF MAJ. RANGE	JUMPER POSITION		
	JS3	JS2	JS1
100 - 90	A	A	A
90 - 79	A	A	B
79 - 68	A	B	A
68 - 57	A	B	B
57 - 46	B	A	A
48 - 35	B	A	B
35 - 24	B	B	A
24 - 11	B	B	B

TABLE 3
COURSE ZERO

PERCENT OF MAJ. RANGE	JUMPER POSITION		
	JZ3	JZ2	JZ1
88 - 74	A	A	A
74 - 63	A	A	B
63 - 52	A	B	A
52 - 40	A	B	B
40 - 29	B	A	A
29 - 17	B	A	B
17 - 6	B	B	A
6 - (-6)	B	B	B

TABLE 4
BURNOUT SELECTION

T/C BURNOUT	JUMPER J4
UPSCALE	A
DOWNSCALE	B

6.52 DEAD BAND

All ADTECH Alarms come with a fixed 0.5% of SPAN DEAD BAND setting. We supply an adjustable DEAD BAND as an option to the unit. This procedure applies only to the optional DEAD BAND adjustment.

The SET POINT should be set per the instructions. Adjust the input to the unit until it goes into an alarm state (RED LED indication). Turn the DEAD BAND potentiometer clockwise (to increase the DEAD BAND beyond your desired setting). Re-adjust the input to the level you want to return to normal alarm state. Adjust the DEAD BAND potentiometer counterclockwise until the unit returns to normal (GREEN LED indication).

6.53 TIME DELAY

ADTECH alarms can be supplied with adjustable TIME DELAY. The function helps prevent nuisance alarms when the input signal is noisy.

The TIME DELAY is adjustable from less than 1 second to a maximum of 25 seconds. Turning the TIME DELAY potentiometer clockwise increases the time delay. Since the adjustment is a blind setting, you adjust to a desired TIME DELAY through repeated trials. Toggle the input value from normal to alarm and measure the time until the relay operates (GREEN to RED LED indication).

TABLE 5
THERMOCOUPLE TYPE SELECTION

T/C TYPE	JUMPER		
	J1	J2	J3
E	-	-	A
J	-	-	B
K,T	-	A	-
N	-	B	-
R,S	A	-	-
B	B	-	-

TABLE 6
TCA 104/105
MAJOR RANGE SELECTION

PERCENT OF MAJ. RANGE	JUMPER		
	JR1	JR2	JR3
1.25 mV	A	B	-
5 mV	A	A	-
20 mV	B	B	-
80 mV	B	A	-

7.0 FIELD TROUBLE SHOOTING GUIDE

This section offers a simple, first level trouble-shooting aid for an apparent instrument malfunction.

The following information is provided for a qualified technician or serviceman as check points for use in internal troubleshooting.

CHECKPOINT (H3 LABEL)	VOLTAGE (Vdc)
+24V	26+/-4
+V	8+/-0.5
+VR	-5+/-0.5
-V	-8+/-0.5
-VR	-5+/-0.25
VNORM1	0 to 5*

Note:

All Test Points Located at Header, (H3).

All Test Points With Respect to "GND" at Head.

*Varies with Zero to Full scale Input

6.43 Recheck ZERO and SPAN values per step 1 and 2 above, and adjust the appropriate controls as necessary.

6.5 ALARM SET POINT, DEAD BAND AND TIME DELAY ADJUSTMENT

Alarm SET POINT, and the optional DEAD BAND and TIME DELAY controls are accessed from the front of the unit. The adjustment procedure is described for one alarm, and applies to each alarm of a dual alarm unit.

6.51 SET POINT

The Alarm SET POINT adjustment is made by applying the desired input value, and adjusting the SET POINT potentiometer until the alarm changes from normal (GREEN LED indication) to alarm (RED LED indication). IT IS VERY IMPORTANT that the potentiometer be adjusted from the non-alarm condition to the alarm condition to insure the proper alarm setting.

**TABLE 1
RELAY ACTION JUMPER SELECTION**

RELAY CONFIGURATION	RELAY	
	K1	K2
Low Alarm	JO3=B	JO4=B
High Alarm	JO3=A	JO4=A
Non-Failsafe	JO1=B	JO2=B
Failsafe	JO1=A	JO2=A

**TABLE 2
COURSE SPAN**

PERCENT OF MAJ. RANGE	JUMPER POSITION		
	JS3	JS2	JS1
100 - 90	A	A	A
90 - 79	A	A	B
79 - 68	A	B	A
68 - 57	A	B	B
57 - 46	B	A	A
46 - 35	B	A	B
35 - 24	B	B	A
24 - 11	B	B	B

**TABLE 3
COURSE ZERO**

PERCENT OF MAJ. RANGE	JUMPER POSITION		
	JZ3	JZ2	JZ1
88 - 74	A	A	A
74 - 63	A	A	B
63 - 52	A	B	A
52 - 40	A	B	B
40 - 29	B	A	A
29 - 17	B	A	B
17 - 6	B	B	A
6 - (-6)	B	B	B

**TABLE 4
BURNOUT SELECTION**

T/C BURNOUT	JUMPER J4
UPSCALE	A
DOWNSCALE	B

6.52 DEAD BAND

All ADTECH Alarms come with a fixed 0.5% of SPAN DEAD BAND setting. We supply an adjustable DEAD BAND as an option to the unit. This procedure applies only to the optional DEAD BAND adjustment.

The SET POINT should be set per the instructions. Adjust the input to the unit until it goes into an alarm state (RED LED indication). Turn the DEAD BAND potentiometer clockwise (to increase the DEAD BAND beyond your desired setting). Re-adjust the input to the level you want to return to normal alarm state. Adjust the DEAD BAND potentiometer counterclockwise until the unit returns to normal (GREEN LED indication).

6.53 TIME DELAY

ADTECH alarms can be supplied with adjustable TIME DELAY. The function helps prevent nuisance alarms when the input signal is noisy.

The TIME DELAY is adjustable from less than 1 second to a maximum of 25 seconds. Turning the TIME DELAY potentiometer clockwise increases the time delay. Since the adjustment is a blind setting, you adjust to a desired TIME DELAY through repeated trials. Toggle the input value from normal to alarm and measure the time until the relay operates (GREEN to RED LED indication).

**TABLE 5
THERMOCOUPLE TYPE SELECTION**

T/C TYPE	JUMPER		
	J1	J2	J3
E	-	-	A
J	-	-	B
K,T	-	A	-
N	-	B	-
R,S	A	-	-
B	B	-	-

**TABLE 6
TCA 104/105
MAJOR RANGE SELECTION**

PERCENT OF MAJ. RANGE	JUMPER		
	JR1	JR2	JR3
1.25 mV	A	B	-
5 mV	A	A	-
20 mV	B	B	-
80 mV	B	A	-

7.0 FIELD TROUBLE SHOOTING GUIDE

This section offers a simple, first level trouble-shooting aid for an apparent instrument malfunction.

The following information is provided for a qualified technician or serviceman as check points for use in internal troubleshooting.

CHECKPOINT (H3 LABEL)	VOLTAGE (Vdc)
+24V	26+/-4
+V	8+/-0.5
+VR	-5+/-0.5
-V	-8+/-0.5
-VR	-5+/-0.25
VNORM1	0 to 5*

Note:

All Test Points Located at Header, (H3).

All Test Points With Respect to "GND" at Head.

*Varies with Zero to Full scale Input

8.0 COMPONENT LAYOUT

FIG. 2

