



ADTECH

95 Mt. Read Blvd # 149
Rochester, New York 14611 USA

www.adtech-inst.com

SAMPLE AND HOLD- MODULE MODEL NO. SHM-60

THE ADTECH MODEL SHM 60 SAMPLE AND HOLD MODULE PROVIDES AN ACCURATE AND ECONOMICAL SINGLE CHANNEL MEMORY OF AN ANALOG PROCESS INPUT SIGNAL.

CONTROL OF THE OUTPUT PROCESS SIGNAL IS NORMALLY DONE THROUGH AN EXTERNAL CONTACT INPUT COMMAND. THE SHM 60'S DIGITAL MEMORY PROVIDES INFINITE HOLD TIME WITH NO DECAY. THE EXTERNAL COMMAND INPUT MAY BE A DRY CONTACT OR SOLID STATE SWITCH RATED 24 VDC AT 2 MA. OR A VOLTAGE PULSE OF 9-30 VDC. SPECIFY CONTACT/SWITCH OR PULSE STATE FOR THE SPECIFIC MODE REQUIRED.

THE SHM 60 OFFERS FOUR MODES OF OPERATION: 1) THE STANDARD "SAMPLE MODE", ALSO CALLED UPDATE MODE, WHERE THE INPUT SIGNAL IS SAMPLED ON THE APPLICATION OF AN EXTERNAL COMMAND AND IS HELD AS THE OUTPUT UNTIL A NEW SAMPLE COMMAND IS RECEIVED; 2) THE "TRACK MODE" WHERE THE OUTPUT FOLLOWS THE INPUT AS LONG AS AN EXTERNAL TRACK COMMAND IS PRESENT, WITH THE OUTPUT SIGNAL HELD AT THE LAST VALUE WHEN THE TRACK COMMAND IS PRESENT, WITH THE OUTPUT SIGNAL HELD AT THE LAST VALUE WHEN THE TRACK COMMAND IS REMOVED; 3) "PEAK PICKER-MODE" AND 4) "VALLEY PICKER MODE." IN THE MODES 3 AND 4, THE SHM 60 RESPONDS TO AN INCREASING AND DECREASING SIGNAL RESPECTIVELY AND HOLDS THE PEAK OR VALLEY SIGNAL LEVEL OUTPUT UNTIL AN EXTERNAL TRACK COMMAND MAKES THE OUTPUT FOLLOW THE INPUT (SPECIFY).

THE SHM PROVIDES STANDARD PROCESS CURRENT OR VOLTAGE SIGNALS ON THE OUTPUT WITH A MAXIMUM OF 10 mV P/P OUTPUT RIPPLE. IT OFFERS A WAY IF INTERFACING PROCESS SIGNALS TO A COMPUTER SYSTEM OR OTHER PROCESS INSTRUMENTATION FOR IMPROVED RESOLUTION.

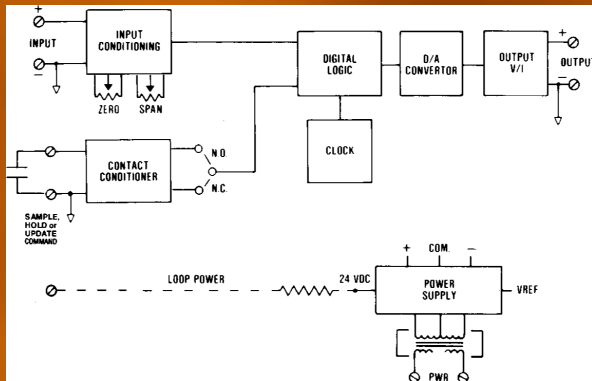

TYPICAL APPLICATIONS

- STORE PERIODICALLY COMPUTED INFORMATION FOR ANALYZERS AND COMPUTERS
- SET POINT MEMORY ON COMPUTER FAILURE
- ANALYZER PEAK SELECTION AND MEMORY

FEATURES

- FOUR MEMORY FUNCTIONS: SAMPLE, TRACK, PEAK AND VALLEY (NULL)
- INFINITE HOLD: DIGITAL TECHNIQUE, 0.02% RESOLUTION
- COMMAND CONTROL: 24 VDC @ 2 MA CONTACT-STANDARD; 0-10 TO 0-24 VDC VOLTAGE-OPTIONAL
- DC CURRENT INPUTS: 4-20 MA, ETC.
- DC VOLTAGE INPUTS: 1-5 VDC, ETC.
- HIGH INPUT IMPEDANCE: 10 MEGOHMS MINIMUM
- ZERO-BASED INPUTS: CURRENT AND VOLTAGE
- LOW IMPEDANCE CURRENT INPUTS: 1/10 STANDARD-OPTIONAL
- DC PROCESS SIGNAL OUTPUTS: CURRENT AND VOLTAGE
- REPEATABILITY: $\pm 0.05\%$ OF SPAN
- HIGH ACCURACY: $\pm 0.1\%$ SPAN



CONNECTIONS / DIMENSIONS

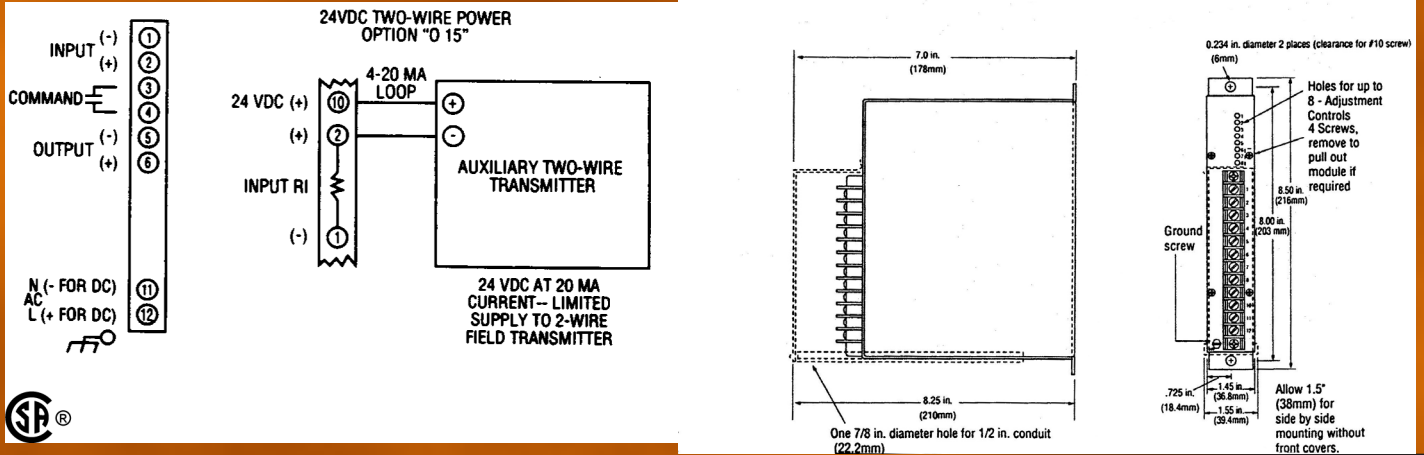

INPUT/OUTPUT

INPUT SIGNALS
 4-20 mA DC (Z IN 250 OHMS)
 10-50 mA DC (Z IN 100 OHMS)
 0-1 mA DC (Z IN 5K OHMS)
 0-10 mA DC (Z IN 500 OHMS)
 1-5 VDC (Z IN 10 MEGOHMS)
 0-5 VDC (Z IN 10 MEGOHMS)
 0-10 VDC (Z IN 1 MEGOHM)

OUTPUT SIGNALS/ OUTPUT DRIVE (RL)

SIGNAL	AC POWER (RL)	DC POWER (RL)
4-20 mA DC	0-1,000 OHMS MAX.	0-(00 OHMS MAX.
10-50 mA DC	0-400 OHMS MAX.	0-350 OHMS MAX.
0-1 mA DC	0-20,000 OHMS MAX.	0-18,000 OHMS MAX.
1-5 VDC	100K OHMS MIN.	100K OHMS MIN.
0-10 VDC	200K OHMS MIN.	200K OHMS MIN.

OTHER ZERO-BASED CURRENT AND VOLTAGES ARE AVAILABLE.
 LOW IMPEDANCE CURRENT INPUTS, 1/10 STANDARD (OPTION I 18)
INPUT COMMANDS
 CONTACT: DRY OR SOLID STATE.
 24 VDC AT 2 MA
 PULSE: 0-9 TO 0-30 VDC (SPECIFY LOGIC STATE)

PERFORMANCE

CALIBRATED ACCURACY: ±0.1%
LINEARITY: ±0.1% MAXIMUM, ±0.04% TYPICAL
REPEATABILITY: ±0.05% MAXIMUM
TEMPERATURE STABILITY: ±0.01% / °F MAXIMUM, ±0.004% / °F TYPICAL
LOAD EFFECT: ±0.01% ZERO TO FULL LOAD
OUTPUT RIPPLE: 10 mV P/P MAXIMUM
RESPONSE TIME: 150 MILLISECONDS
TEMPERATURE RANGE: 0° TO 140 °F (-18° TO 60 °C) OPERATING: -40° TO 185 °F (-40° TO 85 °C) STORAGE
POWER SUPPLY EFFECT: ±0.05% FOR A ±10% POWER VARIATION
 NOTE: ALL ACCURACIES ARE GIVEN AS A PERCENTAGE OF SPAN.

POWER

115 VAC: 50/60 Hz, 0.7 PF (STANDARD)	48 VDC: ISOLATED (OPTION P3)
12 VDC: ISOLATED (OPTION P8)	125 VDC: ISOLATED (105-140 VDC) (OPTION P4)
24 VDC: ISOLATED (OPTION P2)	230 VAC: 50/60 Hz, 0.7 PF (OPTION P5)

NOTE: ALL UNITS 3 WATTS MAXIMUM, AND ±10% POWER VARIATION UNLESS NOTED.

MECHANICAL

ELECTRICAL CLASSIFICATION: GENERAL PURPOSE
CONNECTION: BARRIER TERMINAL STRIP (3/8" SPACING, NO. 6 SCREWS)
CONTROLS: MULTITURN ZERO AND SPAN CONTROLS

MOUNTING: SURFACE MOUNTING STANDARD. SEE HOUSINGS SECTION FOR OPTIONS.
WEIGHT: NET UNIT: 2.6 POUNDS (1.18 KILOGRAMS);
SHIPPING: 3.0 POUNDS (1.36 KILOGRAMS)

OPTIONS

OPTION NUMBER	DESCRIPTION
I 14	VOLTAGE INPUTS TO 200 VDC, 1 MEGOHM MIN. IMPEDANCE; CURRENT INPUTS OF 100 MA MAX.
I 18	LOW IMPEDANCE DC CURRENT INPUT [1/10 OF STANDARD (Z)]
O 10	BIPOLAR CURRENT (LARGER THAN + 1 MA)
O 11	BIPOLAR VOLTAGE TO ±10 VDC: AT 1 MA, BIPOLAR CURRENT ±1 MA
O 15	TWO-WIRE TRANSMITTER EXCITATION
H 11	WIDE-LINE CONDUIT MOUNTING PLATE AND TERMINAL COVER
H 13B, H 14B, H 15B	NEMA 4.7, AND 12 ENCLOSURES
H 16	PFA 12 HIGH-DENSITY, PLUG-IN ENCLOSURES

Ordering Information

- Model number
- Input signal
- Sample, track, peak, or valley function (specify)
- N.O. or N.C. command control, contact or voltage pulse
- Output signal
- Prime power with option no.
- Input/output options
- Housing and miscellaneous options

Please refer to the Housing and/or Option Section for more specific and detailed information.