



ADTECH
 Analog-Digital Technology, Inc.
 95 Mt. Read Blvd Suite 149
 Rochester, New York 14611 USA
 Phone 1.585.698.1845 Fax 1.585.697.0445

DVA 112

DC Current/Voltage Deviation Alarms

Instruction Manual

1.0 INTRODUCTION

These instructions refer to the above model. Supplementary sheets are attached if the unit has special options or features. For detailed specifications, refer to the Data Bulletin. All ADTECH instruments are factory calibrated and supplied with a label detailing the calibration. Adjustments are normally not necessary. A simple check should be performed to verify calibration before installation to ensure that it matches the field requirement.

2.0 GENERAL DESCRIPTION

The ADTECH DVA 112 is a deviation alarm that accepts two process input signals like 1-5 vdc or 4-20 ma dc and provide relay contact output(s) based on deviation limits.

The DVA 112 deviation alarm provides one SPDT output per relay as standard. DPDT output is optionally available and requires the "Wide Line" enclosure. The alarm operates when deviation between the two inputs exceeds a preset set value.

Relay K1 switches when input A just increases over (input B + Deviation). Relay K2 switches when input B just increases over (Input A + Deviation). The above is true for high trip. For low trip, the condition, "just increase over" changes to "just decreases below."

The alarm may be a Hi or Low alarm. Internal jumpers determine the proper relay(s) action.

The relay coil may be power fail safe (i.e.) energized for normal conditions or NON-power fail safe (i.e.) energizes on alarm conditions.

Unless otherwise specified the DVA 112 alarm is set as Hi NFS (High Non-Failsafe).

Red/Green LED indicator(s) for alarm condition are provided. Green indicates normal condition and red indicates alarm condition.

Power Option P-1 Non-Isolated 24 vdc provides negative input signal and negative DC power common rail connection.

3.0 INSTALLATION

The instrument is supplied in a general purpose enclosure as standard. NEMA 4, 7 or 12 and plug in chassis enclosures are optionally available. Installation area/location must agree with the supplied instruments including operating temperature and ambient conditions.

Mounting

Refer to the appropriate outline drawing for mounting and clearance dimensions. The instrument is surface mounted with two #10-32 screws on 8.00 inch centers.

Electrical Connections

The wire used to connect the instrument to the control system **Input/Output**, should be a twisted pair(s) and sized

according to normal practice. Shielded cable is not normally necessary (if used, the shield must be grounded at the input negative of the ADTECH instrument and left floating at the sensor).

A 12 position barrier terminal block with #6-32 screws and 3/8" spacing is provided for **I/O** and power connection. A housing ground terminal marked G is also provided.

Controls

Multiturn trip set control is provided to set the deviation trip point level. Adjustable dead band deviation control(s) are also provided. If optional calibrated dial for trip set or adjustable dead band control(s) is supplied, they are normally mounted in the "Wide Line" enclosure.

The multiturn control(s) is accessible through the instrument front panel and is clearly marked for ease of use.

4.0 MAINTENANCE

These instruments are electronic except for the relay(s) output(s) and require no maintenance except for periodic cleaning and calibration verification. The standard relay is rated by the manufacturer for 500,000 10 amp operations at 30 vdc and 2x10⁷ mechanical operations. Relay output(s) should be verified at user established time intervals. If the unit appears to be mis-operating it should be checked in place per section 6.0 or removed for a bench check per

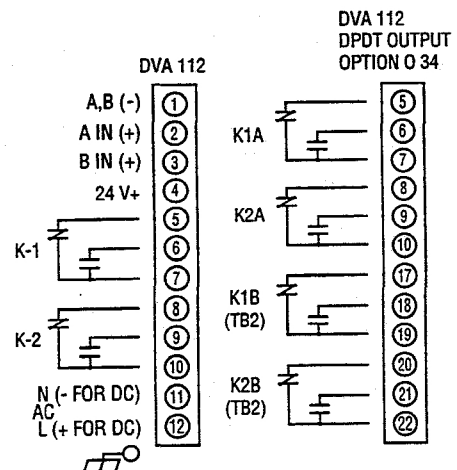

NOTE: K1 TRIPS WHEN A = B + DEV.
 K2 TRIPS WHEN B = A + DEV.

sections 6.0 and 7.0. MOST problems are traced to field wiring and/or associated circuits. If the problem appears to be within the instrument, proceed to sections 6.0 and 7.0.

5.0 CONNECTIONS

Standard connections are shown on page 1 and on the instrument face plate, Data Bulletin or on attached supplementary sheets.

6.0 SETUP AND CALIBRATION PROCEDURE

All ADTECH Alarms are factory calibrated per the customer instructions. Usually, a complete recalibration is not required unless it is required to change input types, relay action, or the range of the unit. Most calibrations will only require an alarm SET POINT adjustment and the associated options like adjustable DEAD BAND or TIME DELAY.

The calibration process is broken into 5 separate steps as follows:

Input and Output Configuration	Section 6.1
Determining the MAJOR RANGE settings	Section 6.2
Determining the COARSE ZERO and SPAN settings	Section 6.3
FINE ZERO and SPAN adjustment	Section 6.4
Alarm SET POINT, DEAD BAND, and TIME DELAY adjustment	Section 6.5

6.1 INPUT AND OUTPUT CONFIGURATION

6.11 Input Configuration

The ADTECH Series 100 Deviation Alarm, DVA 112 accepts both Current and Voltage DC inputs. Refer to the connection diagram for the appropriate connection to the terminal block.

If it is required to change the input configuration, Wire Jumpers J1A, J1B, J2A, J2B, J3A, J3B, J4A and J4B may need to be changed. Consult Table 4 on page 4.

6.12 Deviation Balance Adjustment

If jumpers J1A through J4B are changed, the Deviation Balance may need to be adjusted. The Deviation Balance is only used when the input is either a current or voltage input. Millivolts range requires no deviation balance. If the jumpers are not changed, there is no need to adjust the deviation balance. The Deviation Balance is adjusted as follows:

1. Connect a voltmeter from R3 (-) to R4 (+) on small auxiliary pc board (Refer to figure 2 for locations).
2. Apply the full scale input to both inputs and adjust the potentiometer marked Input Balance until the voltmeter reads 0 Vdc +/- 2mV. This completes Deviation Balance adjustment.

6.13 Output Configuration

All ADTECH series 100 Alarms allow the customer to change the factory set relay action. Both Relays may be configured for LOW trip action or HIGH trip action as required by the particular application. Table 1 shows the jumper settings required to set the appropriate trip action.

In addition to the trip action, the mode in which the relay is energized may be changed. Each Relay may be either set in a FAILSAFE mode (Relay energized under normal, non alarm condition) or NON-FAILSAFE mode (Relay De-energized under normal, non alarm condition) as per

application. Follow Table 1 to set the jumpers for the required application.

Example 1: (standard factory settings)

Both Relays K1 & K2 High trip NFS:

Jumpers J03=A , J04=A
J01=B , J02=B

Example 2:

Both Relays K1, K2), Low trip

FAILSAFE:

J03=B , J04=B
J01=A , J02=A

6.2 DETERMINING MAJOR RANGE

The ADTECH 100 Series Alarms are designed to accept a wide input range. The input is first signal conditioned to a MAJOR RANGE. This ranging technique assures the highest performance from the units and maintains a standard, easy to use calibration method. The customer can then elevate or suppress up to 85% of the MAJOR RANGE with the COARSE ZERO settings, and also scale to less than 15% of the MAJOR RANGE with the COARSE SPAN settings. The FINE ZERO and SPAN controls provide 12% adjustment of the MAJOR RANGE.

The input SPAN and ZERO values are used to select the MAJOR RANGE from table 4. The MAJOR RANGE is determined from the maximum of the SPAN, or ZERO x 1.17 (ignoring the sign). The best way to illustrate this is with a few examples.

Example 1: Inputs = 1 to 5 Vdc
SPAN = (5 - 1) = 4 vdc
ZERO of 1 Vdc x 1.17 = 1.17

Since SPAN value is larger than ZERO value the select the MAJOR RANGE that is greater than or equal to 4 Vdc from table 4 (or 5.12 Vdc).

Example 2: Inputs = -5 to +5 Vdc:
SPAN = [5 - (-5)] = 10
ZERO of 5 x 1.17 = 5.85
(Note: You ignore the sign for MAJOR RANGE selection)

Again, in this example the MAJOR RANGE selection is determined by the SPAN. This would select the 20.48 Vdc MAJOR RANGE from table 4.

Example 3: Inputs = 1 to 1.5 Vdc
SPAN = (1.5 - 1) = 0.5 Vdc
ZERO of 1 x 1.17 = 1.17

Since ZERO number is larger than SPAN, use 1.17 to select from table 4. This would select a MAJOR RANGE of 1280 mV DC.

6.3 COARSE ZERO AND SPAN SETTINGS

Once the MAJOR RANGE is selected, the COARSE ZERO and SPAN settings can be easily determined.

For all deviation inputs, COARSE ZERO is fixed at ±6% of MAJOR RANGE (Jumper settings $JZ_3 = JZ_2 = JZ_1 = B$).

COARSE SPAN: Calculate as follows:

$$\text{Percent major range} = \frac{\text{SPAN VALUE}}{\text{MAJOR RANGE}} \times 100$$

Now, use Table 2 to select the jumpers.

Example 1: Inputs = 1 to 5 Vdc

$$\text{SPAN} = (5 - 1) = 4$$

MAJOR RANGE selected = 5.12 Vdc

$$\text{SPAN as \% of MAJOR RANGE } (4/5.12) \times 100\% = 78.1\%$$

$$\text{ZERO as \% of MAJOR RANGE } (1/5.12) \times 100\% = 19.5\%$$

Simply find the range that includes the percentages just calculated in the appropriate table.

6.4 FINE ZERO AND SPAN ADJUSTMENT

The FINE ZERO and SPAN controls provide an adjustment of 12% of the MAJOR RANGE selected. This is an internal adjustment. A voltmeter with resolution to 1 mV will be required to do the fine adjustment. The procedure is as follows:

1. Connect the voltmeter from GND(-) to VNORM1(+) on the test point header H3 (Refer to figure 2 for locations.) Apply the ZERO input to the unit, and adjust the ZERO ADJ. potentiometer until the test meter reads 0 Vdc +/- 2 mV.
2. Connect the voltmeter from +VR(-) to VNORM1(+) on the test point header. Apply full scale to the unit, and adjust the SPAN ADJ. potentiometer until the test meter reads 0 Vdc +/- 2 mV.
3. Recheck the ZERO and SPAN values per step 1 and 2 above, and adjust the appropriate controls as necessary.

6.5 ALARM SET POINT, DEAD BAND AND TIME DELAY ADJUSTMENT

Alarm SET POINT, and the optional DEAD BAND and TIME DELAY controls are accessed from the front of the unit. The adjustment procedure is described for one set point, and applies to each set point of a dual alarm unit.

**TABLE 1
RELAY ACTION
JUMPER SELECTION**

RELAY CONFIGURATION	RELAY	
	K1	K2
Low Alarm	J03=B	J04=B
High Alarm	J03=A	J04=A
Non-Failsafe	J01=B	J02=B
Failsafe	J01=A	J02=A

Both relays must be high alarm or low alarm.

**TABLE 2
COURSE SPAN**

PERCENT OF MAJ. RANGE	JUMPER		
	JS3	JS2	JS1
100 - 90	A	A	A
90 - 79	A	A	B
79 - 68	A	B	A
68 - 57	A	B	B
57 - 46	B	A	A
46 - 35	B	A	B
35 - 24	B	B	A
24 - 11	B	B	B

Set Point

The Alarm SET POINT adjustment is made by applying the desired input value, and adjusting the SET POINT potentiometer until the alarms changes from normal (GREEN LED indication) to (RED LED indication). IT IS VERY IMPORTANT that the potentiometer be adjusted from the non-alarm conditions to the alarm condition to insure the proper alarm setting. (If you reverse the adjustment direction, you are really adjusting for the SET POINT plus the DEAD BAND.) Repeat the above step near the SET POINT to get precise adjustment.

Dead Band

All ADTECH Alarms come with a fixed DEAD BAND of 0.5% of SPAN. An adjustable DEAD BAND as an option is available. This procedure applies only to the optional DEAD BAND adjustment.

After the SET POINT is set per the instructions, adjust the input to the unit until it goes into an alarm state (RED LED indication). Turn the DEAD BAND potentiometer clockwise (to increase the DEAD BAND beyond your desired setting). Re-adjust the input to the level for return to normal alarm state. Adjust the DEAD BAND potentiometer counterclockwise very slowly until the unit returns to normal (GREEN LED indication).

Time Delay

ADTECH alarms can be supplied with adjustable TIME DELAY option. This feature helps prevent nuisance alarms when the input signal is noisy.

The TIME DELAY is adjustable from less than 1 second to a maximum of 25 seconds. Turning the TIME DELAY potentiometer clockwise increases the time delay. Since the adjustment is a blind setting, adjust to a desired TIME DELAY through repeated trials. Toggle the input value from normal to alarm and measure the time until the relay operates (GREEN to RED LED indication).

7.0 FIELD TESTS

The following information is provided for a qualified technician or serviceman as check points for use in internal troubleshooting.

CHECKPOINT (H3 LABEL)	VOLTAGE (Vdc)
+24V	26 +/-4
+V	8 +/-0.5
+VR	5 +/-0.25
-V	-8 +/-0.5
-VR	-5 +/-0.25
VNORM1	0 to 5*

NOTE: See table 4 on page 4.

8.0 COMPONENT LAYOUT

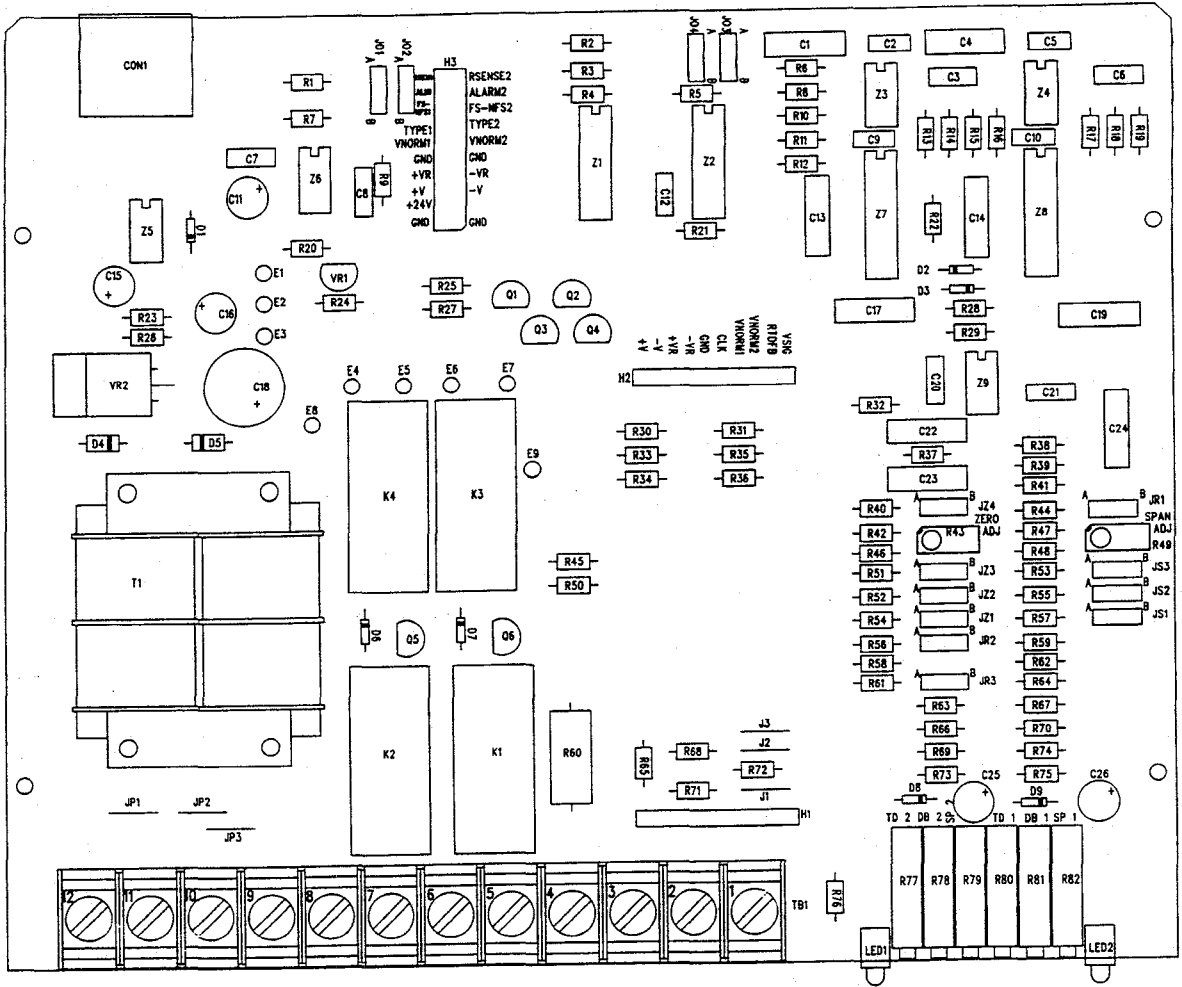

9.0 OUTLINE & MOUNTING

INPUT TYPE	MAJOR RANGE	JUMPER								
		J1A, J1B	J2A, J2B	J3A, J3B	J4A, J4B	JR1	JR2	JR3		
mV	1.25	-	IN	-	-	-	A	B	-	
	5	-	IN	-	-	-	A	A	-	
	20	-	IN	-	-	-	B	B	-	
	80	-	IN	-	-	-	B	A	-	
	320	-	IN	-	-	-	B	-	B	
VOLTS	1280	-	IN	-	-	-	B	-	A	
	5.12	IN	-	IN	-	-	B	B	-	
	20.48	IN	-	IN	-	-	B	A	-	
	81.92	IN	-	IN	-	-	B	-	B	
CURRENT (mA)	327.66*	IN	-	IN	-	-	B	-	A	
	1	-	IN	IN	IN	IN	B	B	-	
	4	-	IN	IN	IN	IN	B	A	-	
	16	-	IN	IN	IN	IN	B	-	B	
64	-	IN	IN	IN	IN	B	-	A		

* Maximum applied input is 250Vdc.

TABLE 4: DVA 112 MAJOR RANGE JUMPER SELECTIONS

