



ADTECH

95 Mt. Read Blvd # 149
Rochester, New York 14611 USA
Phone: 1.585.698.1845
Fax: 1.585.697.0445

www.adtech-inst.com

ANALOG MULTIPLIER MODULE MODEL NO. AXB 53

THE ADTECH MODEL AXB 53 ANALOG MULTIPLE MODULE PROVIDES AN ACCURATE AND ECONOMICAL MEANS OF ACCEPTING TWO PROCESS INPUTS AND MULTIPLYING ONE BY THE OTHER, $K_{AB}=D$. IT PROVIDES AN OUTPUT SIGNAL SUCH AS 4-20 MA DC, 1-5 VDC, OR A ZERO-BASED OUTPUT REPRESENTING THE COMPUTATION.

AN EXCLUSIVE OUTPUT OPTION (O 44) PROVIDES A PULSE RATE OUTPUT ALONG WITH THE STANDARD ANALOG OUTPUT. THIS ELIMINATES THE NEED FOR A SEPARATE LINEAR INTEGRATOR, LIT 56, IF THE OUT IS TO BE TOTALIZED.

THE AXB 53 PROVIDES STANDARD PROCESS CURRENT OR VOLTAGE SIGNALS ON THE OUTPUT WITH A MAXIMUM OF 10 mV P/P OUTPUT RIPPLE. IT OFFERS AN EASY AND PRACTICAL WAY OF INTERFACING PRODUCT SIGNALS TO A COMPUTER SYSTEM OR OTHER PROCESS INSTRUMENTATION FOR IMPROVED RESOLUTION.

RECALIBRATION TO OTHER DESIRED RANGES IS CONVENIENT. THE USE OF TEMPERATURE-STABLE, LOW-NOISE COMPONENTS PROVIDES EXCELLENT STABILITY AND NOISE IMMUNITY.

THE AXB 53 EMPLOYS THE LATEST DESIGN AND COMPONENTS UTILIZING PROVEN TECHNIQUES FOR SUPERIOR RELIABILITY, ACCURACY, AND SERVICEABILITY.

AS COMPANION INSTRUMENTS, ADTECH ALSO OFFERS TWO MODELS WITH THREE ANALOG INPUTS AND ONE OUTPUT.

MDB 52 IS SUITABLE FOR COMPUTING EQUATIONS SUCH AS $(A \times B)/C$.

AN MFM 32 IS SPECIFICALLY DESIGNED TO COMPUTE COMPENSATED MASS FLOW, FROM INPUTS OF P OR LINEAR FLOW TRANSMITTER, TEMPERATURE, AND PRESSURE TRANSMITTERS.

ALL OF THESE PRODUCTS OFFER THE OPTIONAL PULSE RATE OUTPUT: OPTION O 44.

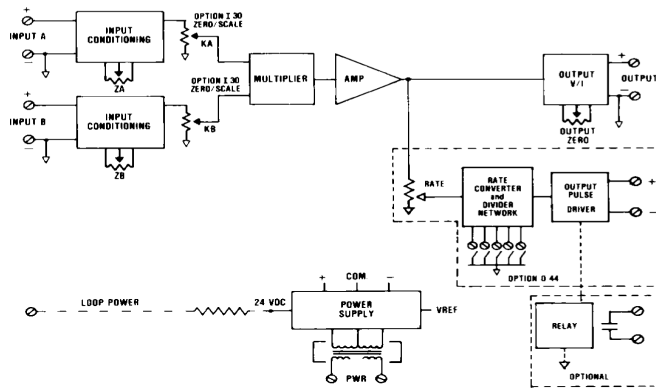

FEATURES

- BASIC EQUATION: $K_{AB} = D$
- DC CURRENT INPUTS: 4-20 mA, ETC.
- DC VOLTAGE INPUTS: 1-5 VDC, ETC.
- HIGH-INPUT IMPEDANCE: 10 MEGOHMS MINIMUM
- ZERO-BASED INPUTS: CURRENT AND VOLTAGE
- DC PROCESS SIGNAL OUTPUTS: CURRENT AND VOLTAGE
- REPEATABILITY: +0.02% OF SPAN
- HIGH ACCURACY: +0.1% OF SPAN
- SPAN ADJUSTMENT: 0-100% BOTH INPUTS
- ZERO SUPPRESSION: 0-100% BOTH INPUTS--OPTIONAL

TYPICAL APPLICATIONS

- MODULATED CONTROL
- PRESSURE COMPENSATION
- EQUATION SOLVING
- BTU COMPUTER



CONNECTIONS / DIMENSIONS

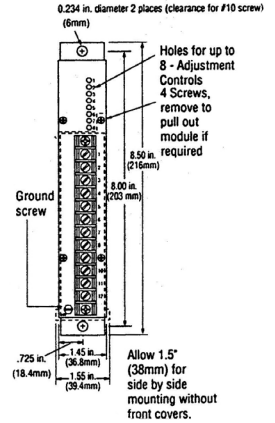
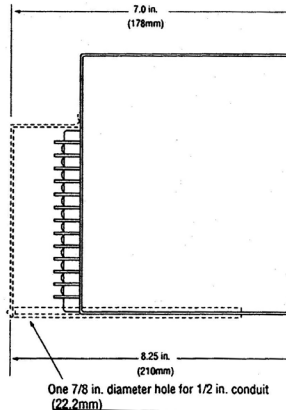
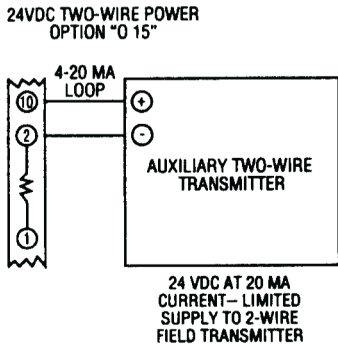
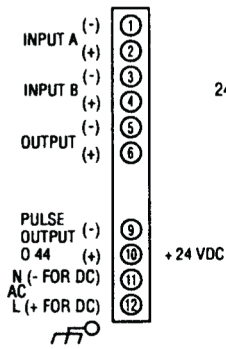

INPUT/OUTPUT

INPUT SIGNALS
 4-20 mA DC (Z IN 250 OHMS)
 10-50 mA DC (Z IN 100 OHMS)
 0-1 mA DC (Z IN 5K OHMS)
 0-10 mA DC (Z IN 500 OHMS)
 1-5 VDC (Z IN 10 MEGOHMS)
 0-5 VDC (Z IN 10 MEGOHMS)
 0-10 VDC (Z IN 1 MEGOHM)
 OTHER ZERO-BASED CURRENT AND VOLTAGES ARE AVAILABLE.

OUT PUT SIGNALS / OUTPUT DRIVE (RL)	
SIGNAL	AC POWER (RL)
4-20 mA DC	0-1,000 OHMS MAX.
10-50 mA DC	0-400 OHMS MAX.
0-1 mA DC	0-20,000 OHMS MAX
1-5 VDC	100K OHMS MIN
0-10 VDC	200K OHMS MIN

DC POWER (RL)
 0-900 OHMS MAX.
 0-350 OHMS MAX.
 0-18,000 OHMS MAX
 100K OHMS MIN.
 200K OHMS MIN.

PERFORMANCE

CALIBRATED ACCURACY: $\pm 0.1\%$ REFERRED TO INPUT
 LINEARITY: $\pm 0.1\%$ MAX., $\pm 0.04\%$ TYPICAL
 REPEATABILITY: $\pm 0.05\%$ MAXIMUM
 TEMPERATURE STABILITY: $\pm 0.01\%/^{\circ}\text{F}$,
 $\pm 0.004\%/^{\circ}\text{F}$ TYPICAL
 LOAD EFFECT: $\pm 0.01\%$ ZERO TO FULL LOAD
 OUTPUT RIPPLE: 10 mV P/P MAXIMUM
 RESPONSE TIME: 150 MILLISECONDS
 NOTE: ALL ACCURACIES ARE GIVEN AS A PERCENTAGE OF SPAN

TEMPERATURE RANGE: 0° TO 140°F (-18° TO 60°C)
 OPERATING: -40° TO 185°F (-40° TO 85°C) STORAGE
 POWER SUPPLY EFFECT: $\pm 0.05\%$ FOR A
 $\pm 10\%$ POWER VARIATION

POWER

115 VAC: 50/60 HZ, 0.7 PF (STANDARD)
 12 VDC: ISOLATED (OPTION P8)
 24 VDC: NON-ISOLATED (OPTION P1)
 24 VDC: ISOLATED (OPTION P2)

48 VDC: ISOLATED (OPTION P3)
 125 VDC: ISOLATED (105-140 VDC) (OPTION P4)
 230 VAC: 50/60 HZ, 0.7 PF (OPTION P5)

NOTE: ALL UNITS 3 WATTS MAXIMUM, AND A $\pm 10\%$ POWER VARIATION UNLESS NOTED.

MECHANICAL

ELECTRICAL CLASSIFICATION: GENERAL PURPOSE
 CONNECTION: BARRIER TERMINAL STRIP (3/8" SPACING, NO. 6 SCREWS)
 CONTROLS: MULTITURN INPUT ZERO, OUTPUT ZERO, KA, KB, ZA, AND ZB CONTROLS AND OPTIONAL RATE CONTROL
 MOUNTING: SURFACE MOUNTING STANDARD. SEE HOUSINGS SECTION FOR OPTIONS.
 WEIGHT: NET UNIT: 2.6 POUNDS (1.18 KILOGRAMS); SHIPPING: 3.0 POUNDS (1.6 KILOGRAMS)

OPTIONS

OPTION NUMBER	DESCRIPTION
I 14	VOLTAGE INPUTS TO 200 VDC, 1 MEGOHM MIN IMPEDANCE; CURRENT INPUTS OF 100 MA MAX.
I 18	LOW IMPEDANCE DC CURRENT INPUTS (1/10 OF STANDARD Z)
I 30	ZERO SUPPRESSION
O 10	BIPOLAR CURRENT (LARGER THAN ± 1 MA)
O 11	BIPOLAR VOLTAGE TO ± 10 VDC; AT 1 MA, BIPOLAR CURRENT ± 1 MA
O 12	REVERSE CALIBRATION
O 15	TWO-WIRE TRANSMITTER EXCITATION
O 17	INTERNAL MERCURY-WETTED RELAY
O 21	VOLTAGE PULSE- SPECIFY VOLTAGE
O 44	PULSE OUTPUT
O 59	10-1,000 CPS OUTPUT (WITH OPTION O44)
H 10	THIN-LINE CONDUIT MOUNTING PLATE AND TERMINAL COVER
H 13B, H 14B, H 15B	NEMA 4.7, AND 12 ENCLOSURES
H 16	PFA 12 HIGH-DENSITY, PLUG-IN ENCLOSURES

Ordering Information

- Model number
- Input signal--bias
- Output signal
- Prime power with option no.
- Input/output options
- Housing and miscellaneous options

Please refer to the Housing and/or Option Section for more specific and detailed information.