



**ADTECH**  
Analog-Digital Technology, Inc.

95 Mt. Read Blvd Suite 149  
Rochester, New York 14611 USA  
Phone 1.585.698.1845 Fax 1.585.697.0445

**AIM 37**  
**Non-Isolated Analog Integration Module**  
**Instruction Manual**

**1.0 INTRODUCTION**

These instructions refer to the above model. Supplementary sheets are attached if the unit has special options or features. For detailed specifications, see page 4 or refer to the Data Bulletin. All ADTECH instruments are factory calibrated and supplied with a label detailing the calibration. Adjustments are normally not necessary. A simple check should be performed to verify calibration before installation to ensure that it matches the field requirement.

**2.0 GENERAL DESCRIPTION**

The ADTECH AIM 37 is a Non-Isolated Analog Integration Module that accepts a process input signal of 1-5 vdc or 4-20 ma dc and computes the analog integral of the input variable and converts it into any of the standard control signal outputs such as 4-20 ma dc.

The AIM 37 offers three modes of operation. In the standard mode, "Averaging Over a Long Period," the output is updated at a selectable rate. Alternatively, the update pulse may also be applied externally; as specified. Typical application for this mode is calculation of average flows, pressures, or levels.

Optionally the AIM 37 may be specified with a "Track Mode" feature. In this configuration the output is continuously changing and represents the true integral (area under the curve) of the input since the last reset (Option I 41). The reset is performed externally with a reset command.

In the "Window Average Mode" (Option I 42) the leading edge of the window command resets the internal electronic counter and starts the integration of the input. The trailing edge of the window command latches the result in the output which represents the area under the input curve for the duration of the window. This mode is useful in calculating the area under the curve for chromatograph components.

The update or reset pulse can be either a transitional pulse or standard contact input.

Power Option P-1 Non-Isolated 24 vdc provides negative output signal and negative DC power common rail connection.

The output is a true current source and provides process signals such as 4-20 ma, 0-1 ma, 0-10 ma, 1-5 ma and 10-50 ma dc or alternatively, a voltage signal of 5 vdc full scale. Other current and voltage Inputs/Outputs (I/O) are available as specified on the Data Bulletin.

**3.0 INSTALLATION**

The instrument is supplied in a general purpose enclosure as standard. NEMA 4, 7 or 12 and plug in chassis enclosures are optionally available. Installation area/location must agree with the supplied instruments including operating temperature and ambient conditions.

**Mounting**

Refer to the appropriate outline drawing for mounting and clearance dimensions. The instrument is surface mounted with two #10-32 screws on 8.00 inch centers.

**Electrical Connections**

The wire used to connect the instrument to the control system I/O should be a twisted pair(s) and sized according to normal practice. Shielded cable is not normally necessary (if used, the shield must be grounded at the input negative of the ADTECH instrument and left floating at the sensor).

A 12 position barrier terminal block with #6-32 screws and 3/8" spacing is provided for I/O and power connection. A housing ground terminal marked G is also provided.

**Controls**

Multiturn INPUT ZERO, OUTPUT ZERO, SPAN and TIME controls are provided to calibrate the instrument. The multiturn controls are accessible through the instrument front panel and are clearly marked for ease of use.

**4.0 MAINTENANCE**

These instruments are electronic and require no maintenance except periodic cleaning and calibration verification. If the unit appears to be mis-operating it should be checked as installed per section 6.0 or removed for a bench check per sections 6.0-7.0. MOST problems are traced to field wiring and/or associated circuits. If the problem appears to be with the instrument, proceed to sections 6.0 and 7.0.

**5.0 CONNECTIONS**

Standard connections are shown below and on the instrument face plate, Data Bulletin or on attached supplementary sheets.

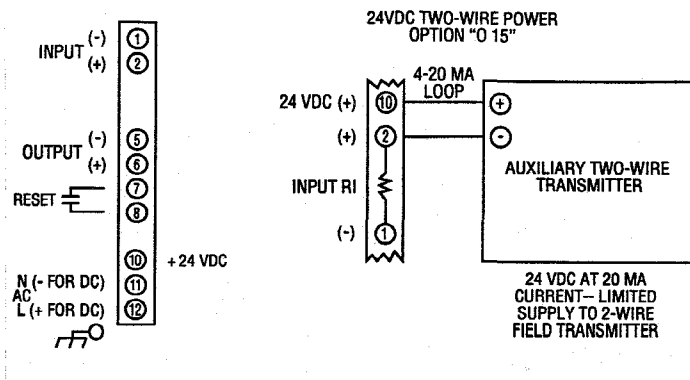

## 6.0 CALIBRATION

To perform a calibration check or re-calibration of the instrument follow this procedure. If the integrating period is relatively long (more than 30 seconds) proceed to Section 6.1.

- A. Make sure the I/O wiring is properly connected and that the correct power source per the label is also connected. The instrument must be at nominal power for a minimum of 2 minutes before proceeding to B.
- B. Set the input source to minimum calibrated input (e.g.)  $4.00 \pm 0.01$  ma and adjust the multiturn potentiometer marked OUT-ZERO to provide the minimum calibrated output (e.g.)  $4.00 \pm 0.01$  ma dc.
- C. Set the input source to maximum input value and wait for the output to update. After the second update the output should show full span value.

### NOTE:

Adjustment of the SPAN potentiometer will show the complete change in the output after two updates.

## 6.1 RECALIBRATION TO A DIFFERENT INTEGRATING TIME OR DIFFERENT I/O.

- A. Remove the instrument from the housing to gain access to the jumpers J13, J14 and J17 taking normal safety and equipment precautions.
- B. Consult the I/O Tables in Section 8.0 and install any components that need to be changed.
- C. From the Integrating Time Period Table note the value of n and T desired and calculate the frequency to be set at pin #4 of Z5 ( $f = n/T$  Hz).
- D. With a frequency meter set to read from pin #4 of Z5 to Terminal #1(-) adjust the multiturn potentiometer marked TIME to provide the value of the frequency calculated in step C.
- E. If not already present, add jumpers J13 and J14 and remove J17 (J15 and J16 should already be present). This sets the integrating time to minimum.
- F. Set the input source to the minimum calibrated value and adjust the multiturn potentiometer marked IN-ZERO to provide 0.000 vdc at pin #1 of Z8 from Terminal #1(-).
- G. With the input source set as in step F, adjust the multiturn potentiometer marked OUT-ZERO to provide the minimum calibrated output (e.g.)  $4.00 \pm 0.01$  ma dc.
- H. Set the input source to the maximum value and adjust the multiturn potentiometer marked SPAN to provide full span output (e.g.)  $20.00 \pm 0.01$  ma dc. Turn instrument power off.
- I. Delete/add the jumpers as per the Integrating Time Period Table for the period selected. This will increase the integrating time T to the desired value.
- J. Turn the instrument power on and set the input source to maximum value. The output should update at the desired integrating period. After two updates the output should be 100% of span.
- K. This completes the calibration.

## 7.0 FIELD TROUBLE SHOOTING GUIDE

This section offers a simple, first level trouble-shooting aid for an apparent instrument malfunction.

<u>SYMPTOM</u>	<u>CORRECTIVE ACTION</u>
No output	<ol style="list-style-type: none"><li>1. Check the input and output connections carefully.</li><li>2. Check that the power supply polarity is correct and that power is present on the instrument terminals.</li><li>3. Check that the input source(s) is correct and that it changes magnitude between zero and full scale values when so adjusted.</li><li>4. If the output is a current signal (4-20 ma, etc.), make sure the output loop is complete and that the correct meter range is selected.</li></ol>

All external checks are complete. Problem seems to be internal.

The following information is provided for a qualified technician or serviceman as check points for use in internal troubleshooting.

<u>CHECKPOINT/ COMPONENT</u>	<u>VOLTAGE/ RANGE</u>
(across) C19	$12 \pm 0.6$ vdc
(across) C20	$26 \pm 4$ vdc
(across) VR1	$6.9 \pm 0.35$ vdc
(across) R79	0.2 - 1 vdc

## 8.0 TABLES, PCB LAYOUT

**INPUT TABLE**

INPUT SIGNAL FULL SCALE	INPUT SHUNT RI
50 ma dc	100 ohm, 1/2 W
20 ma dc	250 ohm, 1/2 W
10 ma dc	499 ohm
1 ma dc	4.99K ohm
10 vdc	See Note 1
5 vdc	None

All selected resistors are 1%, M.F., 1/4 W, 50 PPM, unless otherwise noted.

NOTE 1: R61 = 150 K, R60 = 100 K

NOTE 2: For true zero inputs add R34 = 2 M

NOTE A: Components as shown may or may not be present on the p.c. board due to design updates or options.

**INTEGRATING PERIOD TABLE**

C1 (Pf)	J17	J13	J14	Period sec. T	n
2100	-	X	X	2 - 4	8,192
	-	-	X	4 - 8	16,384
	-	X	-	8 - 16	32,768
100	-	-	-	16 - 29	65,536
	X	X	X	29 - 58	2,097,152
	X	-	X	58 - 126	4,194,304
	X	X	-	126 - 252	8,388,608
2100	X	-	-	252 - 504	16,777,216
	X	X	X	504 - 1008	2,097,152
	X	-	X	1008 - 2016	4,194,304
	X	X	-	2016 - 4032	8,388,608
X	-	-	4032 - 8064	16,777,216	

(X) = Present      (-) = Absent

**OUTPUT TABLE**

OUTPUT SIGNAL FULL SCALE	OUTPUT SHUNT RL	FEEDBACK RES RF
50 ma dc	NONE	20 ohm
20 ma dc	NONE	49.9 ohm
10 ma dc	NONE	100 ohm
1 ma dc	NONE	1K ohm
10 vdc	804 ohm, 1/4 W	49.9 ohm
5 vdc	250 ohm, 1/2 W	49.9 ohm

All selected resistors are 1%, M.F., 1/4 W, 50 PPM, unless otherwise noted.

AIM 37      RI = R62      RL = R86      RF = R84

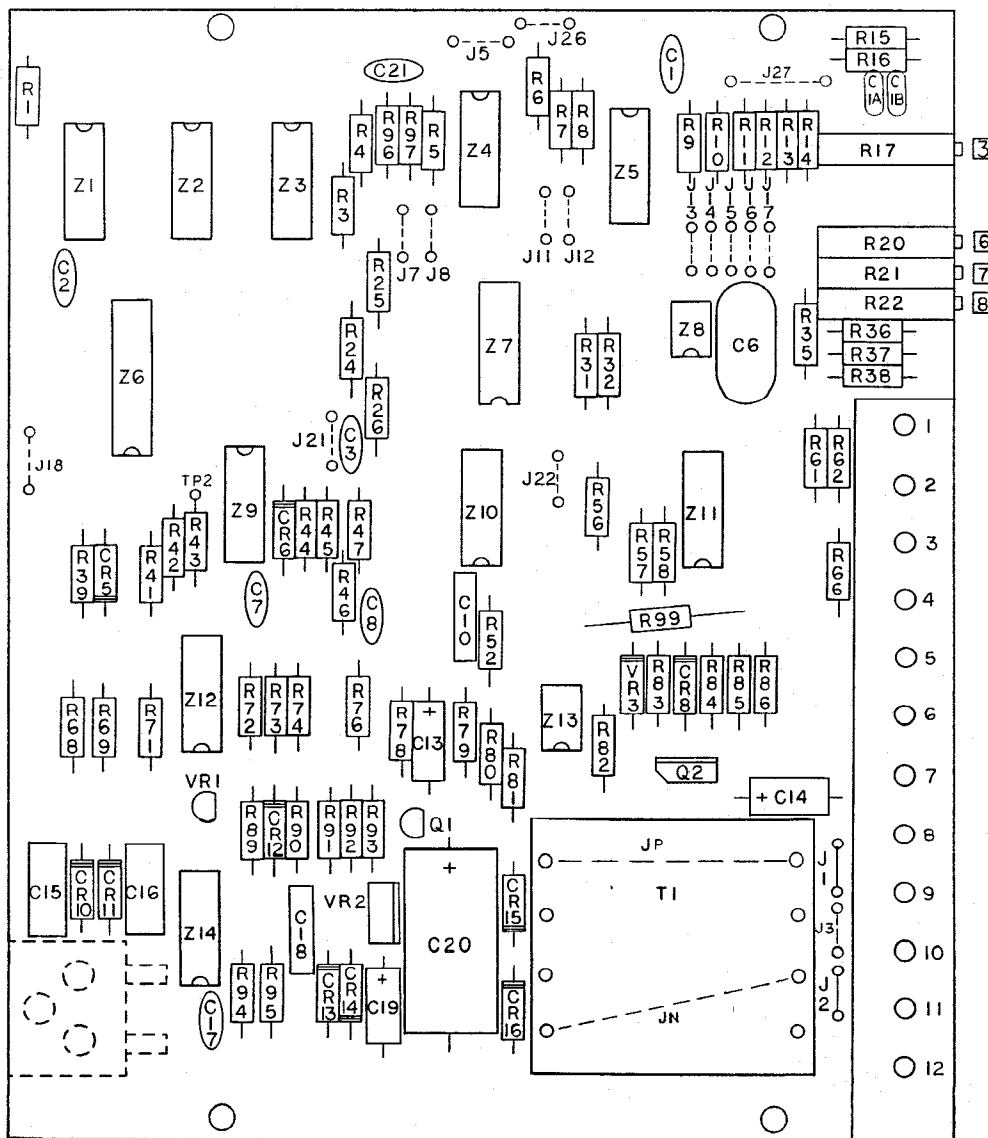

## 9.0 SPECIFICATIONS

### INPUT/OUTPUT

#### INPUT SIGNALS

- 4-20 ma dc (Z in 250 ohms)
- 10-50 ma dc (Z in 100 ohms)
- 0-1 ma dc (Z in 5K ohms)
- 0-10 ma dc (Z in 500 ohms)
- 1-5 vdc (Z in 10 megohms)
- 0-5 vdc (Z in 10 megohms)
- 0-10 vdc (Z in 100K ohms)
- Other zero based current and voltages available
- Low impedance current inputs, 1/10 standard (Option I 18)

#### OUTPUT SIGNALS/OUTPUT DRIVE

	AC Power	DC Power
a. 4-20 ma dc	0-1000 ohms max.	0-900 ohms max.
b. 10-50 ma dc	0-400 ohms max.	0-350 ohms max.
c. 0-1 ma dc	0-20,000 ohms max.	0-18,000 ohms max.
d. 1-5 vdc	250 ohms Z out	250 ohms Z out
e. 0-10 vdc	500 ohms Z out	500 ohms Z out

Zero based current and voltages in the above ranges are standard (e.g.) 0-20 ma, 0-5 vdc. Other voltage and currents optional.

#### PERFORMANCE

- Calibrated Accuracy:**  $\pm 0.1\%$
- Linearity:**  $\pm 0.1\%$  maximum,  $\pm 0.04\%$  typical
- Repeatability:**  $\pm 0.05\%$  maximum
- Temperature Stability:**  $\pm 0.01\%/^{\circ}\text{F}$  maximum,  $\pm 0.004\%/^{\circ}\text{F}$  typical
- Load Effect:**  $\pm 0.01\%$  zero to full load
- Output Ripple:** 10 mv P/P maximum
- Response Time:** One integration period
- Temperature Range:** 0° to 140°F (-18° to 60°C) operating  
-40° to 185°F (-40° to 85°C) storage
- Power Supply Effect:**  $\pm 0.05\%$  for a  $\pm 10\%$  power variation

Note: All accuracies are given as a percentage of span

#### POWER

- 115 vac:  $\pm 10\%$ , 50/60 Hz, 3 watts, 0.7 Pf (standard)
- 24 vdc:  $\pm 10\%$  non-isolated, 3 watts (Option P1)
- 24 vdc:  $\pm 10\%$  isolated, 3 watts (Option P2)
- 48 vdc:  $\pm 10\%$  isolated, 3 watts (Option P3)
- 125 vdc: Nominal (105-140 vdc) isolated, 3 watts (Option P4)
- 230 vac:  $\pm 10\%$ , 50/60 Hz, 3 watts, 0.7 PF (Option P5)

## 10.0 OUTLINE & MOUNTING

