



ADTECH
 Analog-Digital Technology, Inc.
 95 Mt. Read Blvd Suite 149
 Rochester, New York 14611 USA
 Phone 1.585.698.1845 Fax 1.585.697.0445

ADB 51 Non-Isolated Analog Divider Module Instruction Manual

1.0 INTRODUCTION

These instructions refer to the above model. Supplementary sheets are attached if the unit has special options or features. For detailed specifications, see page 4 or refer to the Data Bulletin. All ADTECH instruments are factory calibrated and supplied with a label detailing the calibration. Adjustments are normally not necessary. A simple check should be performed to verify calibration before installation to ensure that it matches the field requirement.

2.0 GENERAL DESCRIPTION

The ADTECH ADB 51 is a Non-Isolated Divider Module that accepts two process input signals of 1-5 vdc or 4-20 ma dc, dividing one by the other ($K \frac{A}{B} = D$) and provides a standard control signal output such as 4-20 ma dc representing the computation. Option O 44 provides an additional pulse output.

Power Option P 1 Non-Isolated 24 vdc provides negative output signal and negative DC power common rail connection.

The output is a true current source and provides process signals such as 4-20 ma, 0-1 ma, 0-10 ma, 1-5 ma and 10-50 ma dc or alternatively, a voltage signal of 5 vdc full scale. Other current and voltage **Inputs/Outputs (I/O)** are available as specified on the Data Bulletin.

3.0 INSTALLATION

The instrument is supplied in a general purpose enclosure as standard. NEMA 4, 7 or 12 and plug in chassis enclosures are optionally available. Installation area/location must agree with the supplied instruments including operating temperature and ambient conditions.

Mounting

Refer to the appropriate outline drawing for mounting and clearance dimensions. The instrument is surface mounted with two #10-32 screws on 8.00 inch centers.

Electrical Connections

The wire used to connect the instrument to the control system I/O should be a twisted pair(s) and sized according to normal practice. Shielded cable is not normally necessary (if used, the shield must be grounded at the input negative of the ADTECH instrument and left floating at the sensor).

A 12 position barrier terminal block with #6-32 screws and 3/8" spacing is provided for I/O and power connection. A housing ground terminal marked G is also provided.

Controls

Multiturn OUTPUT ZERO, KA, KB, ZA, ZB and Optional RATE controls are provided to calibrate the instrument. The multiturn controls are accessible through the instrument front panel and are clearly marked for ease of use. Two Internal INPUT SPAN multiturn controls are also provided.

4.0 MAINTENANCE

These instruments are electronic and require no maintenance except periodic cleaning and calibration verification. If the unit appears to be mis-operating it should be checked as installed per section 6.0 or removed for a bench check per sections 6.0-7.0. MOST problems are traced to field wiring and/or associated circuits. If the problem appears to be with the instrument, proceed to sections 6.0 and 7.0.

5.0 CONNECTIONS

Standard connections are shown below and on the instrument face plate, Data Bulletin or on attached supplementary sheets.

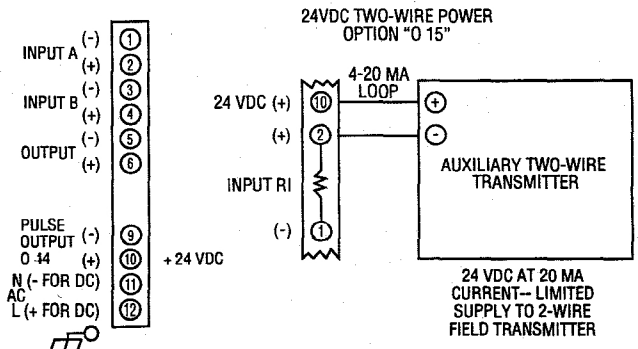

6.0 CALIBRATION

To perform a calibration check or re-calibration of the instrument follow this procedure.

- A. Carefully remove the instrument from the housing to gain access to the PC board components, observing normal safety and equipment precautions.
- B. Make sure the I/O wiring is properly connected and that the correct power source per the label is also connected. The instrument must be at normal power for a minimum of 2 minutes before proceeding to C.
- C. The input signal source(s) must be adjustable from 0 to 100% in steps of 10% or at least 25%. The source(s) should be either precalibrated or an accurate meter must be used to monitor the input(s).
- D. The output may be monitored either as a direct voltage for a voltage output signal or as a current that can be represented as a voltage across a resistor shunt.
- E. Set input source A to the minimum calibrated input and adjust the multiturn potentiometer marked ZA to provide 0.000 vdc from TP1(+) to Terminal #1(-).
- F. Set input source A to the maximum value and adjust the internal multiturn potentiometer R32 to provide 0.000 vdc from TP1(+) to +VREF(+). Also adjust the multiturn potentiometer marked KA fully CW.
- G. Repeat E and F until within $\pm .005V$.
- H. Set input source B to the minimum calibrated input and adjust the multiturn potentiometer marked ZB to provide 0.000 vdc from TP2(+) to Terminal #1(-).
- I. Set the input source B to maximum value and adjust the internal multiturn potentiometer R29 to provide 0.000 vdc from TP2(+) to +VREF(-). Also adjust the multiturn potentiometer KB fully CW.
- J. Repeat G and H until within $\pm .005V$.
- K. Set input source A at the minimum input value, input source B at the maximum value and adjust the multiturn potentiometer OUT-ZERO to provide the minimum calibrated output (e.g.) 4.00 ± 0.01 ma dc.
- L. Set input sources A and B at the maximum input values and adjust the multiturn potentiometer marked KA to provide the maximum calibrated output (e.g.) 20.00 ± 0.01 ma dc.
- M. The unit should now be checked for linearity as follows.
 1. Set input source B to the maximum input and check the output by changing the input source A. The output should follow the input A linearly.
 2. Set input source A at the 25% value of the input span and check the output by changing the input source B. The output should be at 50% when source B is at 50% and the output should be 100% when the source B is at 25%.
- N. This completes the calibration.

NOTE:

If recalibration to a different input and/or output signal is required, proceed to the tables listed under Section 8.0.

6.1 PULSE OUTPUT

If the ADB 51 has been supplied with Option O 44 pulse output refer to O 44 Supplement sheet for calibration details.

7.0 FIELD TROUBLE SHOOTING GUIDE

This section offers a simple, first level trouble-shooting aid for an apparent instrument malfunction.

SYMPTOM CORRECTIVE ACTION

- | | |
|-----------|--|
| No output | <ol style="list-style-type: none">1. Check the input and output connections carefully.2. Check that the power supply polarity is correct and that power is present on the instrument terminals.3. Check that the input source(s) is correct and that it changes magnitude between zero and full scale values when so adjusted.4. If the output is a current signal (4-20 ma, etc.), make sure the output loop is complete and that the correct meter range is selected. |
|-----------|--|

All external checks are complete. Problem seems to be internal.

The following information is provided for a qualified technician or serviceman as check points for use in internal troubleshooting.

<u>CHECKPOINT/ COMPONENT</u>		<u>VOLTAGE/ RANGE</u>
(across)	C25	26 ± 4 vdc
(across)	C29	12 ± 0.6 vdc
(across)	VR1	6.9 ± 0.35 vdc
(across)	R26	0.2 - 1 vdc

8.0 TABLES, PCB LAYOUT

INPUT TABLE

INPUT SIGNAL FULL SCALE	INPUT SHUNT RI
50 ma dc	100 ohm, 1/2 W
20 ma dc	250 ohm, 1/2 W
10 ma dc	499 ohm
1 ma dc	4.99K ohm
10 vdc	See Note 1
5 vdc	None

All selected resistors are 1%, M.F.,
1/4 W, 50 PPM, unless otherwise noted

NOTE 1: Input A R61 = 150 K R60 = 100 K
Input B R64 = 150 K R62 = 100 K

OUTPUT TABLE

OUTPUT SIGNAL FULL SCALE	OUTPUT SHUNT RL	FEEDBACK RES RF
50 ma dc	NONE	20 ohm
20 ma dc	NONE	49.9 ohm
10 ma dc	NONE	100 ohm
1 ma dc	NONE	1K ohm
10 vdc	604 ohm, 1/4 W	49.9 ohm
5 vdc	250 ohm, 1/2 W	49.9 ohm

All selected resistors are 1%, M.F., 1/4 W, 50 PPM, unless otherwise noted.

NOTE A: Components as shown may or may not be present on the p.c. board due
to design updates or options.

ADB 51 RI = R58,63 RL = R85 RF = R29

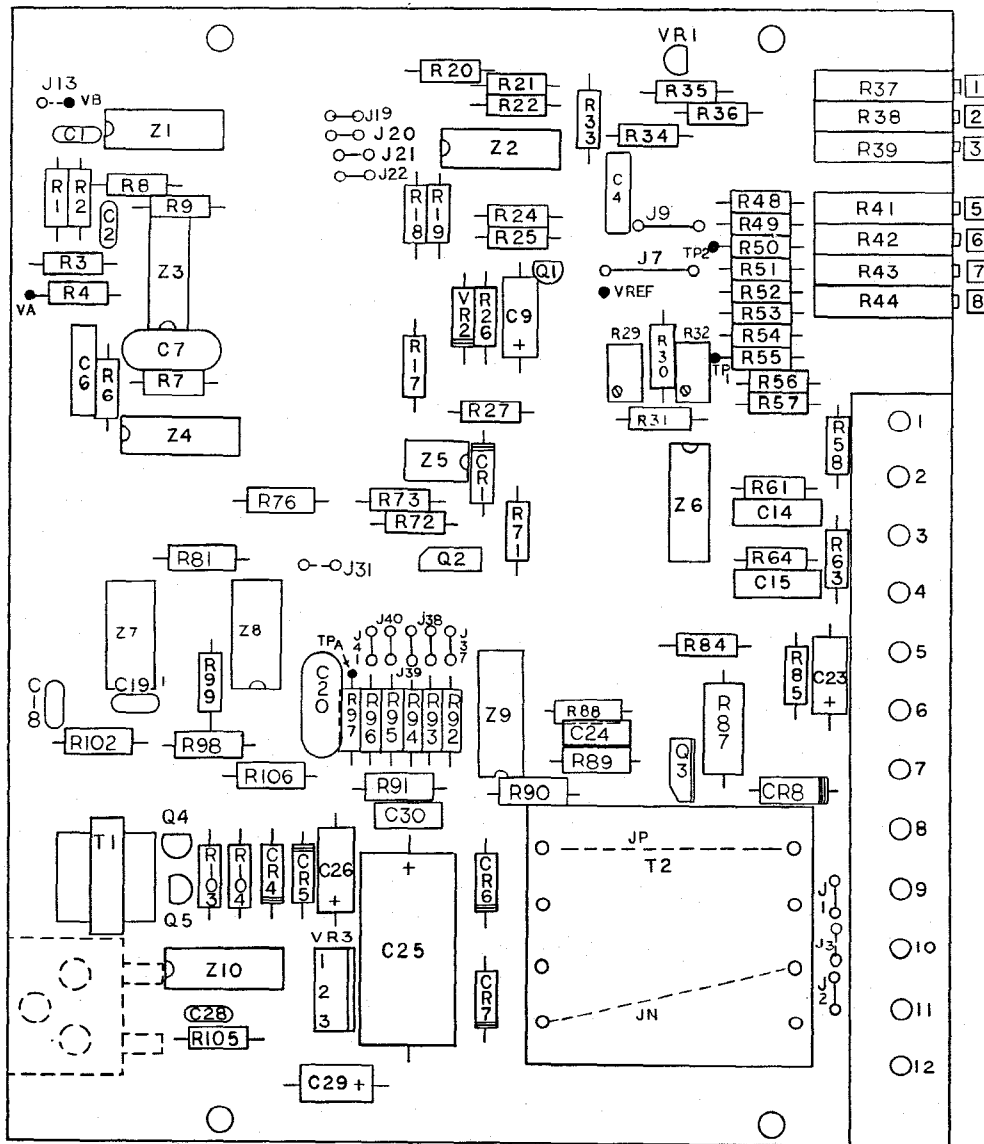

9.0 SPECIFICATIONS

INPUT/OUTPUT

INPUT SIGNALS

- 4-20 ma dc (Z in 250 ohms)
 - 10-50 ma dc (Z in 100 ohms)
 - 0-1 ma dc (Z in 5K ohms)
 - 0-10 ma dc (Z in 500 ohms)
 - 1-5 vdc (Z in 10 megohms)
 - 0-5 vdc (Z in 10 megohms)
 - 0-10 vdc (Z in 100K ohms)
 - Other zero based current and voltages available
 - Low impedance current inputs, 1/10 standard (Option I 18)
- Note: (Input B range limited to 10%-100%)

OUTPUT SIGNALS/OUTPUT DRIVE

	AC Power	DC Power
a. 4-20 ma dc	0-1000 ohms max.	0-900 ohms max.
b. 10-50 ma dc	0-400 ohms max.	0-350 ohms max.
c. 0-1 ma dc	0-20,000 ohms max.	0-18,000 ohms max.
d. 1-5 vdc	250 ohms Z out	250 ohms Z out
e. 0-10 vdc	500 ohms Z out	500 ohms Z out

Zero based current and voltages in the above ranges are standard (e.g.) 0-20 ma, 0-5 vdc. Other voltage and currents optional.

PERFORMANCE

- Calibrated Accuracy:** $\pm 0.1\%$
- Linearity:** $\pm 0.1\%$ X Ratio 1/B
- Repeatability:** $\pm 0.05\%$ maximum
- Temperature Stability:** $\pm 0.01\%/^{\circ}\text{F}$ maximum,
 $\pm 0.004\%/^{\circ}\text{F}$ typical
- Load Effect:** $\pm 0.01\%$ zero to full load
- Output Ripple:** 10 mv P/P maximum
- Response Time:** 150 milliseconds
- Temperature Range:** 0° to 140°F (-18° to 60°C) operating
 -40° to 185°F (-40° to 85°C) storage
- Power Supply Effect:** $\pm 0.05\%$ for a $\pm 10\%$ power variation

Note: All accuracies are given as a percentage of span

POWER

- 115 vac: $\pm 10\%$, 50/60 Hz, 3 watts, 0.7 Pf (standard)
- 24 vdc: $\pm 10\%$ non-isolated, 3 watts (Option P1)
- 24 vdc: $\pm 10\%$ isolated, 3 watts (Option P2)
- 48 vdc: $\pm 10\%$ isolated, 3 watts (Option P3)
- 125 vdc: Nominal (105-140 vdc) isolated, 3 watts (Option P4)
- 230 vac: $\pm 10\%$, 50/60 Hz, 3 watts, 0.7 PF (Option P5)

10.0 OUTLINE & MOUNTING

